

**PULSEO**  
GENERATION

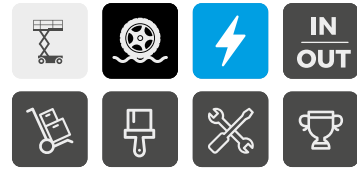

## HS15 E / HS18 E



### HIGH PERFORMANCE & ROUGH TERRAIN CAPACITIES

- > Platform capacity of 750 kg
- > Drive axle with manual locking rear differential increases ground traction

### FULL ELECTRIC DRIVE

- > Silent & clean operations
- > Versatile use: outdoor / indoor
- > Smooth & proportional movements

### MAINTENANCE AND SERVICE-ORIENTED

- > Activ'Screen: on-board configuration & diagnostic interface
- > Easy access to components
- > Haulotte Activ'Energy Management takes care of your battery

### EXTENDED DUTY CYCLES

- > Multiple charging modes including optional accelerated charge
- > Optional & removable, low fuel consumption Range Extender (Stage 5)

# HS15 E / HS18 E

## ELECTRIC ROUGH TERRAIN SCISSOR LIFT

### TECHNICAL DATA

	HS15 E	HS18 E
Working height	15 m	18 m
Platform height	13 m	16 m
Max. drive working height	15 m	13 m
Lift capacity	750 kg (4 pers.)	
Lift capacity on the extension	225 kg	
<b>A</b> Platform length	3.82 m	
Platform length - extended	4.8 m	
<b>B</b> XL platform length - extended (option)	7.4 m	
XL platform length - extended (option)	7.4 m	
Length - extension	0.93 m	
<b>C</b> Platform width - outside	1.89 m	
<b>D</b> Height - stowed	3.05 m	3.15 m
Height - guardrails lowered	2.19 m	2.29 m
<b>E</b> Overall width	2.3 m	
<b>F</b> Length	4.4 m	
<b>G</b> Wheelbase	2.76 m	
<b>H</b> Ground clearance	30.7 cm	
Drive speed	5 km/h	
Gradeability	45 %	40 %
Tilt (lonitudinal / lateral)	5° / 3°	5° / 2°
Turning radius - outside	6.75 m	
Tyres	830 x 285 mm	
Batteries	8 x 6 V - 435 Ah (C20)	
Weight	7 480 kg	8 010 kg

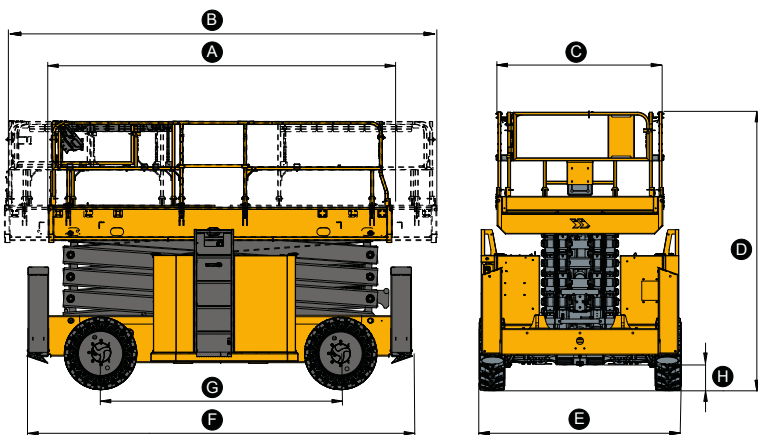

### STANDARD EQUIPMENT

- > 4 wheel drive
- > Folding handrails
- > Mechanical axle with manual locking rear differential
- > Outriggers with centralized or individual controls
- > One platform extension
- > Two drop bar entries
- > Haulotte Activ'Energy Management: smart battery management system & manual centralized watering
- > AC motors
- > 48V battery pack
- > Haulotte Activ'Screen

### OPTIONS AND ACCESSORIES

- > Double swing gate entries
- > Standard platform with dual extensions (5.8 m)
- > XL platform with dual extensions (7.4 m)
- > Range Extender (5.5 kW - Stage 5)
- > Accelerated charger (380 V)
- > Automatic battery water-filling system
- > Cold & arctic weather kits
- > Non marking tires
- > Material handling rack
- > AC power to platform plug (110 / 230 V)
- > Scissors stack protection
- > Platform lighting
- > Work light
- > Telematics holder & predisposition
- > Telematics solutions

